

INSTALLATION INSTRUCTIONS

Each installation may have unique situations that cannot be covered by the following guidelines. Please call 1-800-835-0028 if you have questions.

D01

REV 10/06

- Step 1: Pour floors with block-outs as shown on technical detail. The block-out should be a minimum of 2" wider than the exposed cover width by the specified depth.
- Step 2: Remove the factory- installed #10-24 FHMS from the side covers and retain for reinstallation later.
- Step 3: The extrusion D101 is furnished factory- drilled at 1'-0" on center to be used as a guide for drilling 3/16" dia. holes in the concrete for the Rawl spikes. Locate the extrusion D101 as per the technical detail then drill and drive the Rawl spikes firmly seated against the extrusion.
- Step 4: Reinstall the side cover plates using the #10-24 FHMS.
- Step 5: Lay center cover over side cover with the ends flush. Mark center spring location through cover holes with marking pen. Mark both side covers.
- Step 6: Position the spring assembly in the extruded spring track on the extrusion D101. Pull up to snap in the plastic spring assembly clips into the D101 spring track. Note: the spring assembly will be installed diagonally in the expansion joint. Then slide the spring assembly to align with the location marks from step 5.
- Step 7: Position the center cover plate and install the spring screw to attach the spring assembly to the center cover plate.
- Step 8: Protect exposed surface and then grout in the block-out level with surrounding floor.

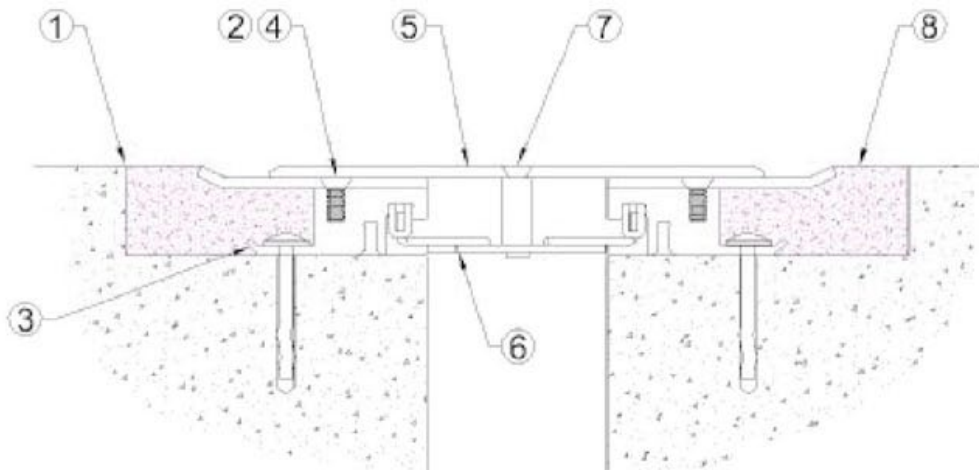

INSTALLATION INSTRUCTIONS

Each installation may have unique situations that cannot be covered by the following guidelines. Please call 1-800-835-0028 if you have questions.

D02

REV 10/06

- Step 1: Pour floors with block-outs as shown on technical detail. The block-out should be a minimum of 1" wider than the exposed cover width by the specified depth.
- Step 2: Remove the factory- installed #10-24 FHMS from the side cover and retain for reinstallation later.
- Step 3: The extrusion D101 is furnished factory- drilled at 1'-0" on center to be used as a guide for drilling 3/16" dia. holes in the concrete for the Rawl spikes. Locate the extrusion D101 as per the technical detail then drill and drive the Rawl spikes firmly seated against the extrusion.
- Step 4: Reinstall the side cover plates using the #10-24 FHMS.
- Step 5: Lay corner cover over side cover with the ends flush. Mark center spring location through corner cover holes with marking pen. **Step 5 – 7 are only required on assemblies that use the spring assembly.**
- Step 6: Position the spring assembly in the extruded spring track on the extrusion D101. Pull up to snap in the plastic spring assembly clips. Then slide the spring assembly to align with the location marks from step 5.
- Step 7: Position the corner cover plate and install the spring screw to attach the spring assembly to the center cover plate.
- Step 8: Locate the wall side of the corner cover plate as per the technical detail. Then drill 3/16" dia. holes and install the 3/16" FH Tapcon fasteners securely.
- Step 9: Protect exposed surface and then grout in the block-out level with surrounding floor.

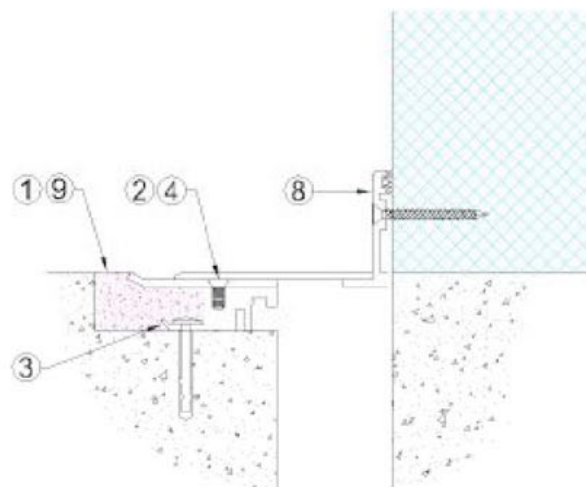

INSTALLATION INSTRUCTIONS

Each installation may have unique situations that cannot be covered by the following guidelines. Please call 1-800-835-0028 if you have questions.

D03

REV 10/06

- Step 1: Remove cover plate and set aside for reinstallation later.
- Step 2: Position wall extrusions and mark locations for drilling through the factory-drilled holes at 2'-0" on center.
- Step 3: Remove the extrusions and drill 3/16" holes.
- Step 4: Fasten extrusions to wall using provided 3/16" x 1 3/4" F.H. Tapcons.
- Step 5: Position cover plate over wall extrusions with ends flush and mark spring locations through cover plate holes with marking pen or scribe.
- Step 6: Position springs in the extrusion spring track aligned with the marks from Step 5. Using 1 1/2" masking tape, hold spring in position by forming a "bridge" under the spring. (Tape one end of tape to one side of the extrusion and pull under the spring, then secure the spring in place by pulling the tape tight under the spring and taping to the other extrusion.)
- Step 7: Install spring screws through holes in center plate into springs at locations marked in Step 5 and tighten.

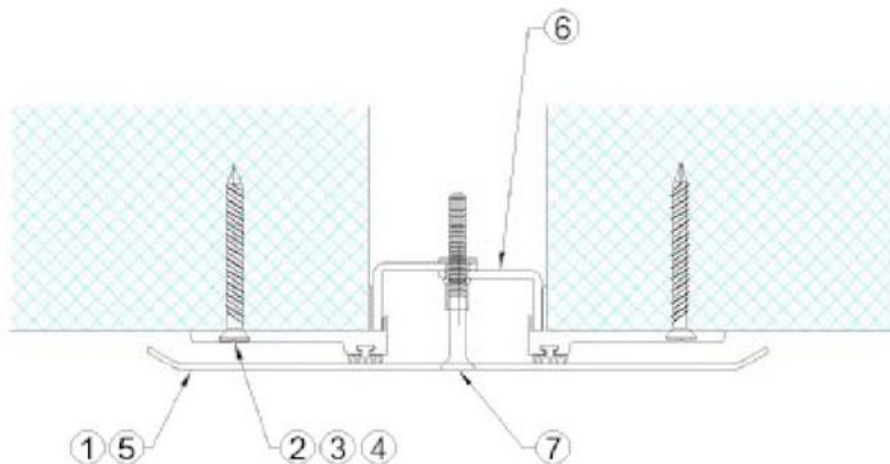

INSTALLATION INSTRUCTIONS

Each installation may have unique situations that cannot be covered by the following guidelines. Please call 1-800-835-0028 if you have questions.

D04

REV 10/06

Step 1: Position the wall anchor extrusion and mark locations for drilling through the factory-drilled holes at 2'-0" on center.

Step 2: Remove wall extrusion and drill 3/16" holes.

Step 3: Fasten extrusion to wall using provided 3/16" x 1 3/4" Tapcons.

Step 4: Position corner cover plate with ends flush and making snug contact with the vinyl seal.

Step 5: Mark locations for drilling through the factory-drilled holes at 2'-0" on center.

Step 6: Remove corner cover plate and drill 3/16" holes.

Step 7: Fasten cover plate using provided 3/16" x 1 3/4" Tapcons.

