

# P Fastners

REV. 8/06

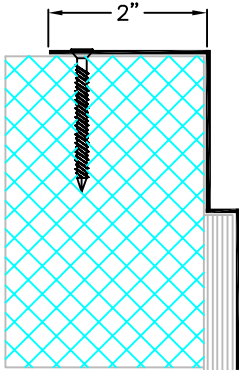

(A) (1" - 2" EJ)

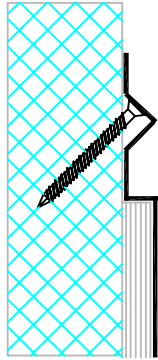

(B) (1" - 2" EJ)

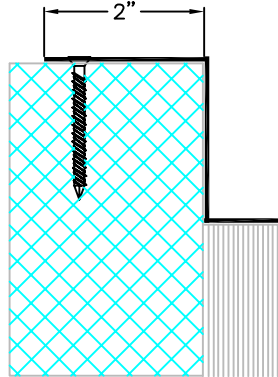

(C) (3" - 18" EJ)

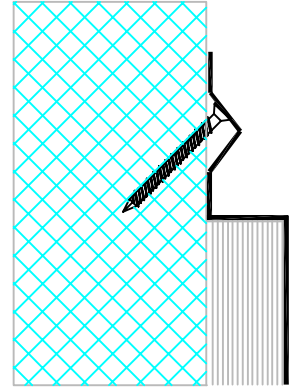

(D) (3" - 18" EJ)

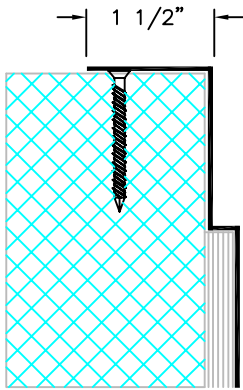

(E) (1" - 2" EJ)

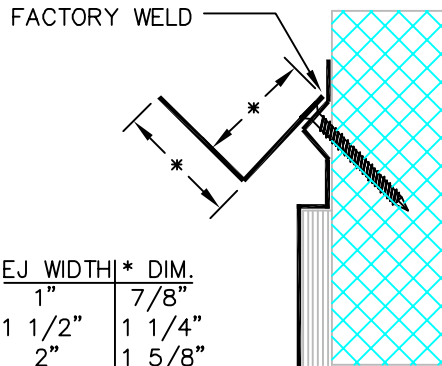

(F) (1" - 2" EJ)

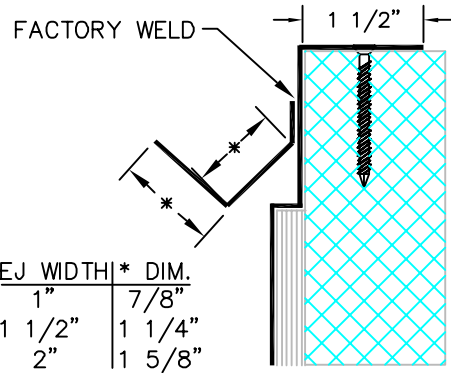

(G) (1" - 2" EJ)

FASTENERS: 3/16" x 1 3/4" F.H. TAPCON @ 1'-6" O.C.  
 FLANGES: 20 GA. GALVANIZED STEEL  
 EXPOSED FINISH: MILL  
 STOCK LENGTHS: 10'-0"

CUSTOMER:		
PROJECT:		
LOCATION:		
ARCHITECT:		
CONTRACTOR:		
NOTE:		
JOB NO.:	DATE:	SCALE: (NTS)

LENGTH:	QTY:	COLOR/FINISH:



**ARCHITECTURAL ART MFG., INC.**



AAMI RESERVES THE RIGHT TO MAKE DESIGN CHANGES, OR TO WITHDRAW ANY DESIGN WITHOUT NOTICE

© COPYRIGHT 2002 AAMI