

## INSTALLATION INSTRUCTIONS

Each installation may have unique situations that cannot be covered by the following guidelines. Please call 1-800-835-0028 if you have questions.

# C01

REV 10/06

- 1: Insert  $\frac{1}{4}$ " x  $2\frac{3}{4}$ " hex head bolts into imbeds and drive tight at 1'-6" on center.
- 2: Position the wall extrusion as dimensioned on technical detail. Mark plastic plug locations at 1'-6" on center. Remove assembly, drill and install plastic plug. Position the wall extrusion and install #10 x 1" F.H.W.S.
- 3: Attach material across assembly for support while placing concrete, and separation material in expansion joint void. (Local conditions will dictate proper material and support method employed.)
- 4: Support as required and pour concrete making sure the expansion joint is plumb and true with required floor line.
- 5: After concrete has cured, remove the expansion joint separation material.
- 6: Remove any concrete residue from all exposed surfaces.
- 7: For floor-to-wall systems, position vinyl inserts and push into extrusion tracks, making sure vinyl is locked into position. To avoid future gaps at ends and intersections, DO NOT stretch vinyl lengthwise during installation.

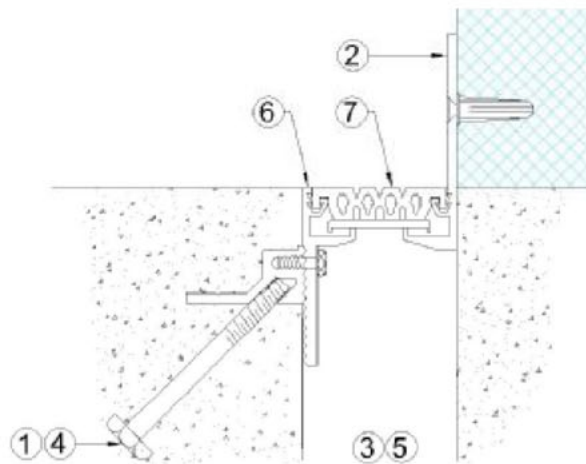
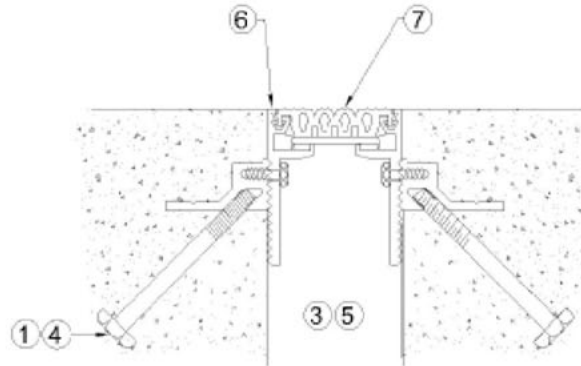

## INSTALLATION INSTRUCTIONS

Each installation may have unique situations that cannot be covered by the following guidelines. Please call 1-800-835-0028 if you have questions.

# C02

REV 10/06

**Step 1:** Pour floors with block-outs as shown on technical detail. The block-outs should be 2 ½" wide by the specified depth.

**Step 2:** The Series "C" assembly is furnished with the floor extrusion drilled at 1'-0" on center to be used as a guide for drilling holes in the precast concrete for Rawl spikes (floor).

**Step 3:** Space, align, mark and drill the precast concrete to accept 3/16" x 1 ½" Rawl spikes.

**Step 4:** Position the wall extrusion as dimensioned on technical detail. Mark plastic plug locations. Remove assembly, drill and install plastic plug. Position the wall extrusion and install #10 x 1" F.H.W.S.

**Step 5:** Insert Rawl spikes into the open locations from Step 3 and drive securely.

**Step 6:** Grout in place level with surrounding floor.

**Step 7:** Remove any concrete residue from all exposed surfaces.

**Step 8:** Position vinyl inserts and push into embed carriers, making sure vinyl is locked into position. To avoid future gaps at ends and intersections, DO NOT stretch vinyl lengthwise during installation.

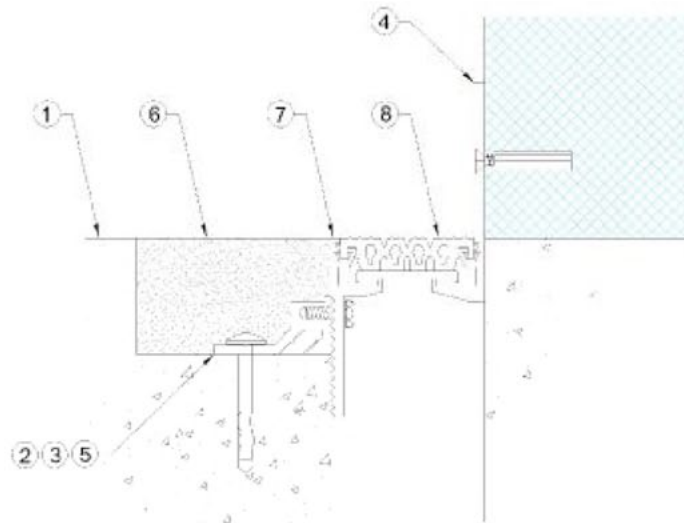
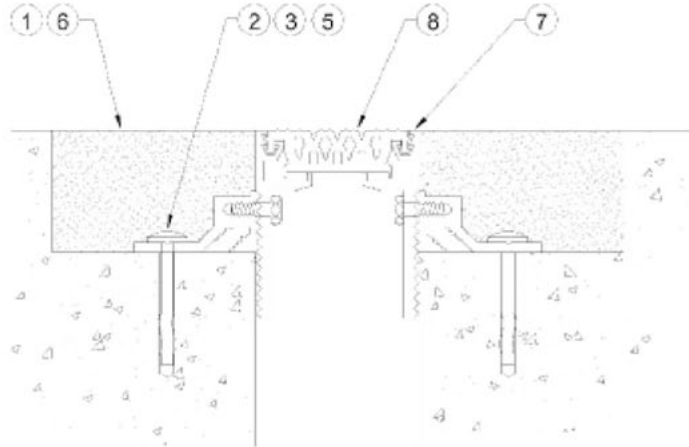

### INSTALLATION INSTRUCTIONS

Each installation may have unique situations that cannot be covered by the following guidelines. Please call 1-800-835-0028 if you have questions.

# C03

REV 10/06

Step 1: Insert  $\frac{1}{4}$ " x 2  $\frac{3}{4}$ " hex head bolts into embeds and drive tight at 1'-6" on center.

Step 2: Remove the vinyl insert and center support.

Step 3: Position the extrusions as dimensioned on technical detail. Drill for the #8 x  $\frac{3}{4}$ " S.M.S. and mark vinyl anchor locations at 1'-6" O.C. Remove assembly, drill and install vinyl anchor. Position the extrusions and install bolts as required.

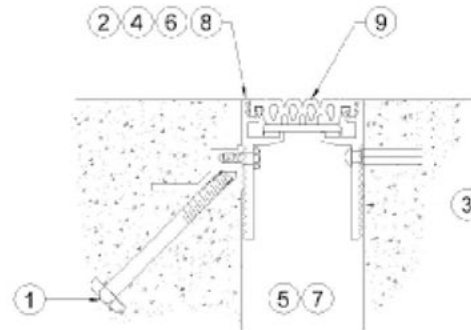

Step 4: Reassemble the support and vinyl insert.

Step 5: Space, align and attach the expansion joint covers to the suspension material.

Step 6: Support as required, protect exposed surfaces and pour concrete making sure the expansion joint is plumb and true with the required floor line.

Step 7: After concrete has cured, remove the expansion joint separation material (if required).

Step 8: Remove any concrete residue from all exposed surfaces.

Step 9: Position vinyl inserts and push into embed carriers, making sure vinyl is locked into position. To avoid future gaps at ends and intersections, DO NOT stretch vinyl lengthwise during installation.

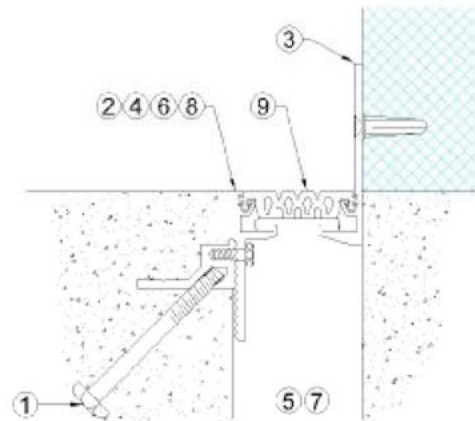

## INSTALLATION INSTRUCTIONS

Each installation may have unique situations that cannot be covered by the following guidelines. Please call 1-800-835-0028 if you have questions.

# C04

REV 10/06

**Step 1:** Pour floors with block-outs as shown on technical detail. The block-outs should be 2 ½" wide by the specified depth.

**Step 2:** The Series "C" assembly is furnished with the floor extrusion drilled at 1'-0" on center to be used as a guide for drilling holes in the precast concrete for Rawl spikes (floor).

**Step 3:** Space, align, mark and drill the precast concrete to accept 3/16" x 1 ½" Rawl spikes.

**Step 4:** Remove the vinyl insert and center support.

**Step 5:** Position the existing floor and wall extrusions as dimensioned on technical detail. Drill for the #8 x 3/4" S.M.S. (5) (Existing) or #10 x 1" F.H.W.S. (5a)(wall) and mark vinyl anchor locations. Remove assembly, drill and install vinyl anchor. Position the extrusions and install screws accordingly.

**Step 6:** Reassemble the vinyl insert and center support.

**Step 7:** Insert Rawl spikes into the open locations from Step 3 and drive securely.

**Step 8:** Grout in place level with surrounding floor.

**Step 9:** Remove any concrete residue from all exposed surfaces.

**Step 10:** Position vinyl inserts and push into embed carriers, making sure vinyl is locked into position. To avoid future gaps at ends and intersections, **DO NOT** stretch vinyl lengthwise during installation.

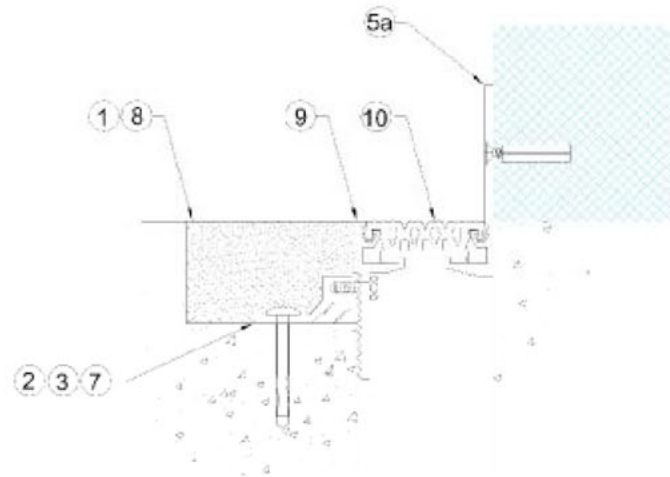
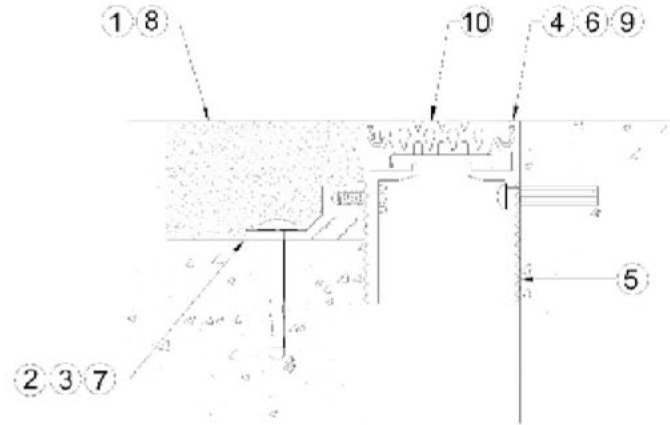

### INSTALLATION INSTRUCTIONS

Each installation may have unique situations that cannot be covered by the following guidelines. Please call 1-800-835-0028 if you have questions.

# C05

REV 10/06

Step 1: Position the assembly, drill for #8 F.H.U.P. and mark plastic plug locations. Remove assembly, drill and install plastic plugs.

Step 2: Position the assembly per plastic plug locations. Install #8 F.H.U.P. in plastic plugs.

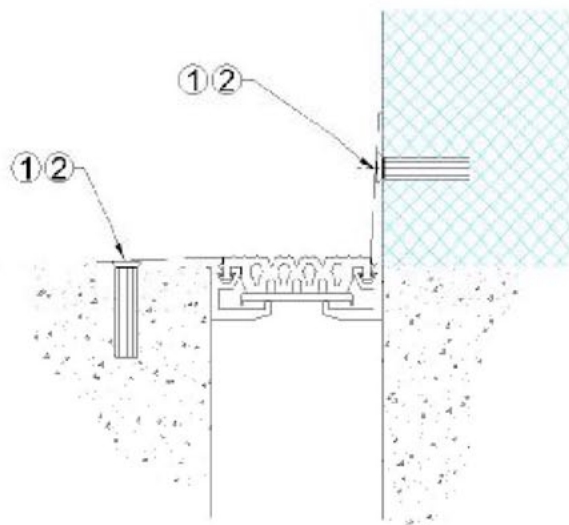
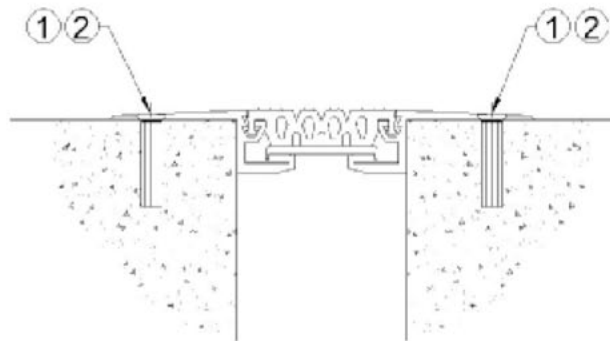

### INSTALLATION INSTRUCTIONS

Each installation may have unique situations that cannot be covered by the following guidelines. Please call 1-800-835-0028 if you have questions.

# C06

REV 10/06

Step 1: Position the assembly, drill for #8 F.H.U.P. and mark plastic plug locations. Remove assembly, drill and install plastic plugs.

Step 2: Position the assembly per plastic plug locations. Install #8 F.H.U.P. in plastic plugs.

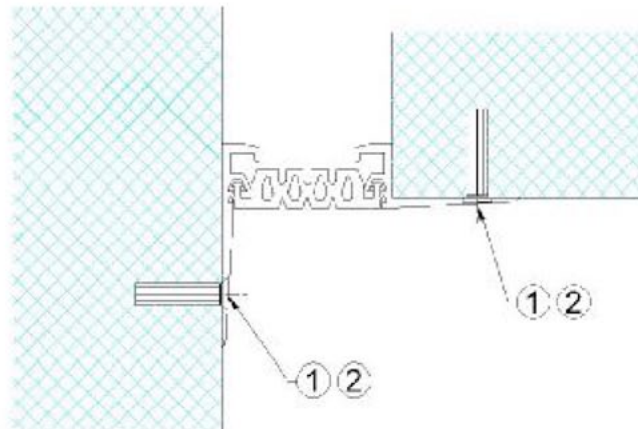
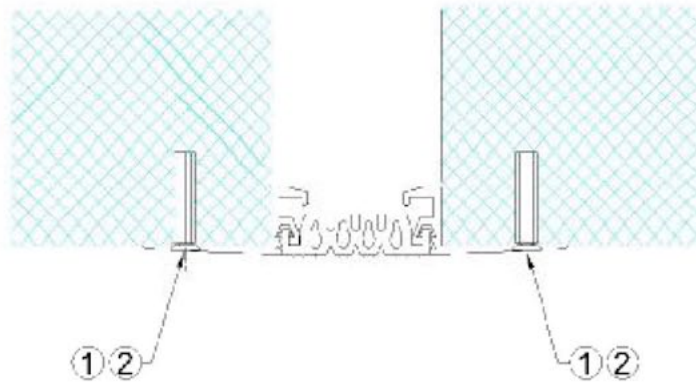

### INSTALLATION INSTRUCTIONS

Each installation may have unique situations that cannot be covered by the following guidelines. Please call 1-800-835-0028 if you have questions.

# C07

REV 10/06

Step 1: Position the assembly, drill for #8 F.H.U.P. and mark plastic plug locations. Remove assembly, drill and install plastic plugs.

Step 2: Position the assembly per plastic plug locations. Install #8 F.H.U.P. in plastic plugs.

