

### INSTALLATION INSTRUCTIONS

Each installation may have unique situations that cannot be covered by the following guidelines. Please call 1-800-835-0028 if you have questions.

# M01

REV 10/06

- Step 1: Pour floors with block-outs for trench. The block-out should have two 3" wide x 1" deep notches in addition to the specified width to allow for the trench cover anchor plate.
- Step 2: Be sure that the block-out is sufficiently deep to receive the form pan, if required, and its surrounding concrete.
- Step 3: Place the trench frame and cover into the block-out, space and align the trench as required.
- Step 4: Drill the precast concrete and anchor plate 1'-0" on center to accept  $\frac{3}{16}$ " x 1  $\frac{1}{2}$ " Rawl spikes. Insert Rawl spikes and drive securely.
- Step 5: Grout in place level with surrounding floor.
- Step 6: Install finish floor in accordance with manufacturers instructions making sure to notch out adequate room for trench cover handle fitting.

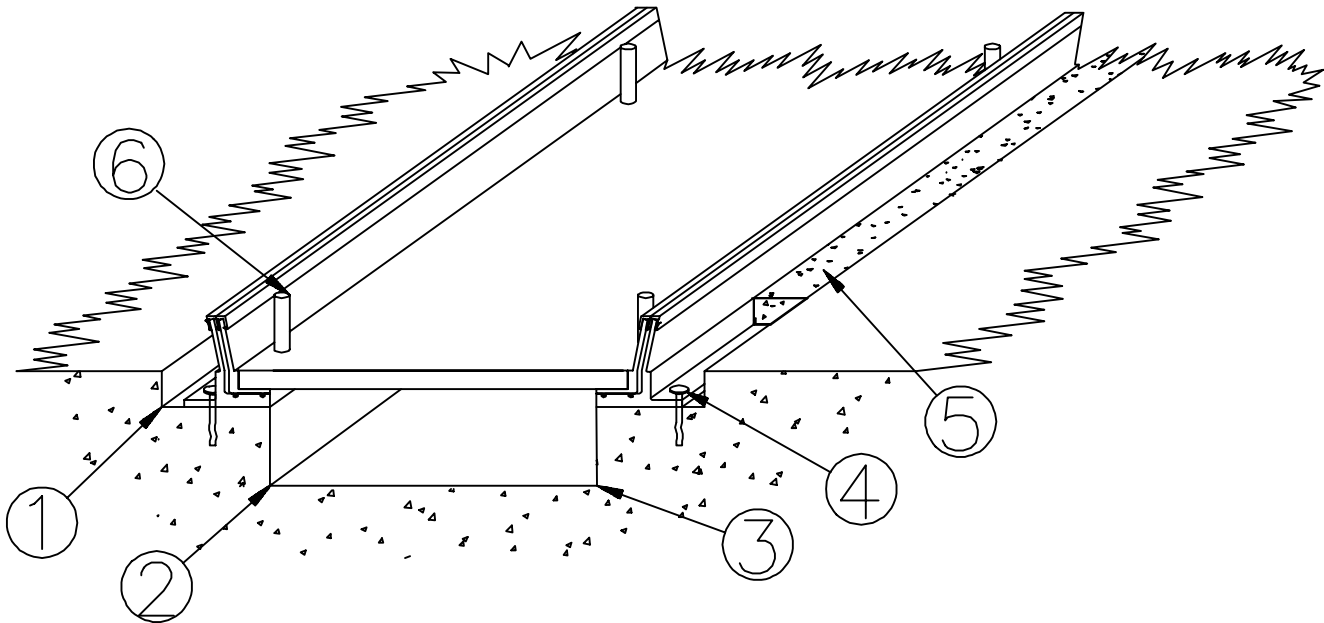

ARCHITECTURAL ART MFG.





## M 30 AND 40 SERIES TRENCH AND ACCESS COVER INSTALLATION

### STEP 1.

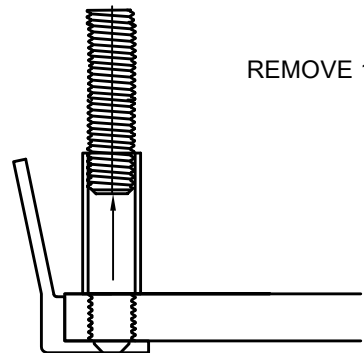

REMOVE 1/2" X 2" SOCKET HEAD SCREW

### STEP 2.

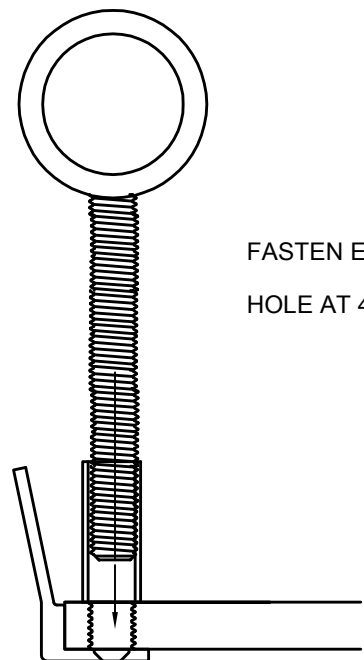

FASTEN EYE BOLT INTO 1/2" THREADED  
HOLE AT 4 LOCATIONS IN ACCESS COVER



STEP 3.

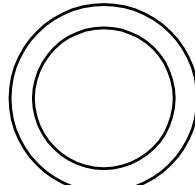

USE EYE BOLTS TO LOWER ACCESS COVER  
ONTO FRAME ALREADY INSTALLED  
THEN REMOVE EYE BOLTS

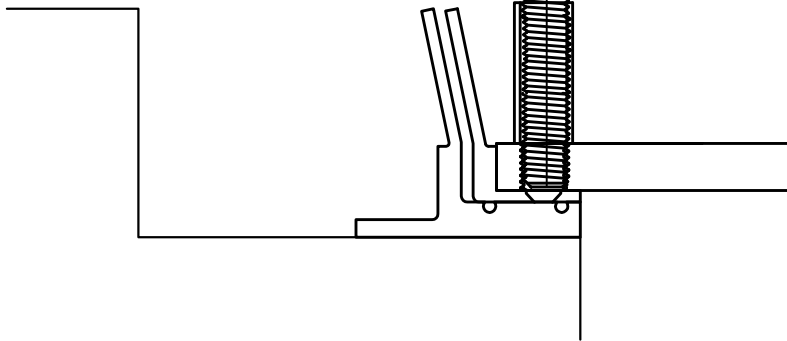

STEP 4.

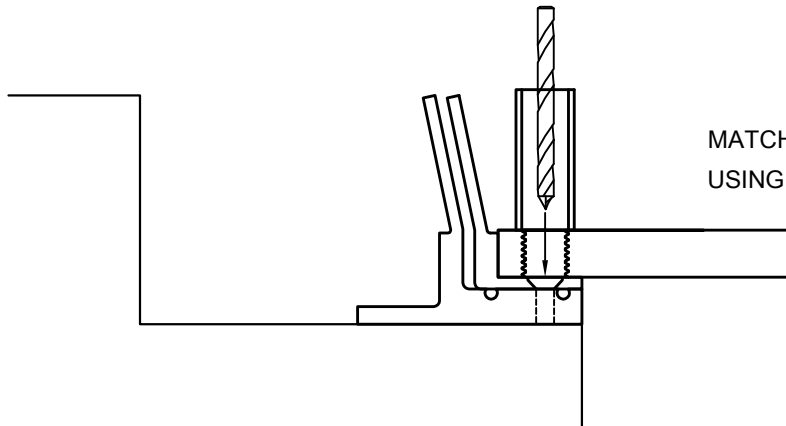

MATCH DRILL FRAME WITH COVER  
USING 11/64 DRILL BIT PROVIDED

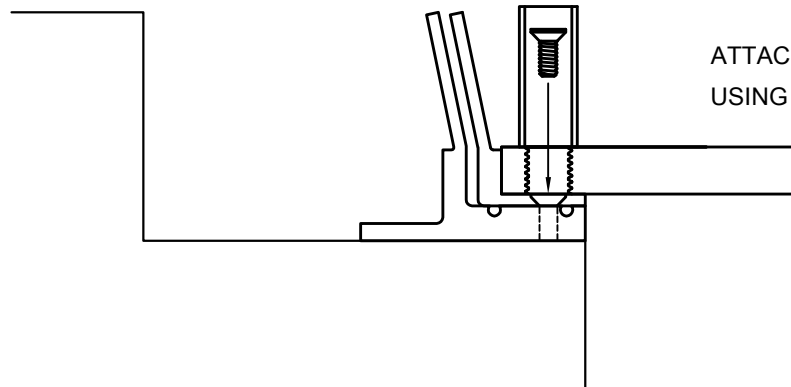

ATTACH COVER TO FRAME AT 4 LOCATIONS  
USING FLAT HEAD SCREW PROVIDED

STEP 6.

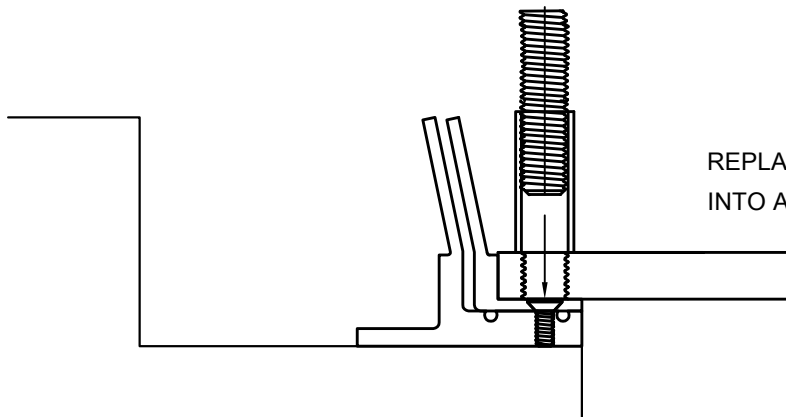

REPLACE 1/2" X 2" SOCKET HEAD SCREW  
INTO ACCESS COVER

STEP 7.

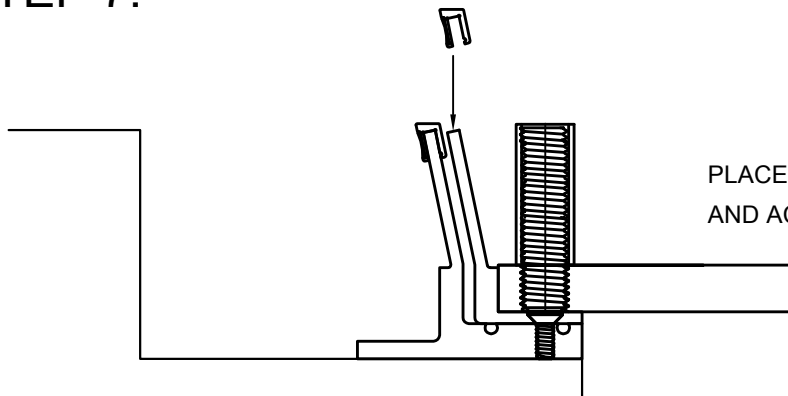

PLACE VINYL CAPS ONTO FRAMES  
AND ACCESS COVERS

### INSTALLATION INSTRUCTIONS

Each installation may have unique situations that cannot be covered by the following guidelines. Please call 1-800-835-0028 if you have questions.

# M02

REV 10/06

- Step 1: Pour floors with block-outs for trench. Trench frames and covers can be set in wood forms, and the entire floor poured at one time, but keeping the frames and cover from floating around is very difficult.
- Step 2: The block-outs should be 8" to 10" wider than the width of the frame itself. Also, allow clearance at the end of the trench.
- Step 3: Be sure that the block-out is sufficiently deep to receive the form pan, if required, and its surrounding concrete.
- Step 4: Be sure that the specified reinforcing steel is in place.
- Step 5: Place the trench frame and cover into the block-out.
- Step 6: Take timber (2x4 or 4x4) and place across the block-out. The timber should be at least one foot longer than the width of the block-out. You will need at least two timbers per unit with a maximum spacing of 5'-0" on center.
- Step 7: Cut two pieces of wire for each timber. Wire should be sufficiently strong to hold the trench frame and cover and resist the vibrating of the concrete. The wire should be long enough to go around the frame anchor and the timber with sufficient lengths on each end to twist the trench frame and cover up to the timber.
- Step 8: Small trench frames and covers may need extra weight to withstand the vibrating of the concrete and hold them in place.
- Step 9: It is always best to feed the concrete on both sides.

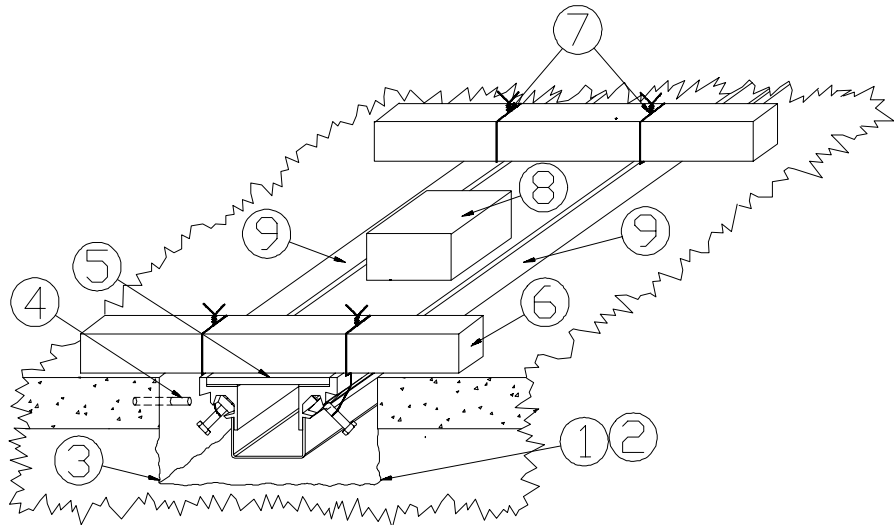

ARCHITECTURAL ART MFG.

